

Shackles





G-209

Shackles



G-2130

What It Takes To Be “Crosby Or Equal”

DESIGN	COMPETITION	CROSBY
<p>The theoretical reserve capability of carbon shackles should be as a minimum 5 to 1, and alloy shackles a minimum of 5 to 1.* Known as the DESIGN FACTOR, it is usually computed by dividing the catalog ultimate load by the working load limit. The ultimate load is the average load or force at which the product fails or no longer supports the load. The working load limit is the maximum mass or force which the product is authorized to support in general service. The design factor is generally expressed as a ratio such as 5 to 1. Also important to the design of shackles is the selection of proper steel to support fatigue, ductility and impact properties.</p>	<p>Ask: What is Working Load Limit and design factor for shackles?</p> <p>Ask: Is deformation upon overloading a critical consideration in their design?</p> <p>Ask: Do they jeopardize other properties by having hardness high in order to increase working load or design factor?</p>	<p>Crosby carbon shackles have the highest design factor (6 to 1) in the industry. All of Crosby's design factors are documented. Crosby purchases only special bar forging quality steel with special cleanliness and guaranteed hardenability. All material chemistry is independently verified prior to manufacturing. The design of Crosby shackles assure that strength, ductility and fatigue properties are met. Load Rated</p>
<p>CLOSED DIE FORGED The proper performance of premium shackles depends on good manufacturing techniques that include proper forging and accurate machining. Closed die forging of shackles assures clear lettering, superior grain flow, and consistent dimensional accuracy. A closed die forged bow allows for an increased cross section that, when coupled with quench and tempering, enhances strength and ductility. Closed die bow forgings combined with close tolerance pin holes assures good fatigue life. Close pin to hole tolerance has been proven to be critical for good fatigue life, particularly with screw pin shackles.</p>	<p>Ask: Are their shackles closed die forged with close tolerance pin holes?</p> <p>Ask: Do their shackles have good fatigue life?</p> <p>Ask: Do their shackles have a fatigue life that meets the new world standards?</p> <p>Many forge bows, utilizing an open die forging process which allows for inconsistent dimensional accuracy and increased pin hole clearance, thus jeopardizing the fatigue life of the shackle in actual use.</p>	<p>Each shackle is closed die forged. Closed die forging produces consistent dimensions. Close tolerance holes and concentric pins with good surface finishes are provided by Crosby and are proven to provide improved fatigue life in actual use. Crosby shackles are fatigue rated as well as load rated. Fatigue Rated</p>
<p>QUENCHED AND TEMPERED Quench and tempering assures the uniformity of performance and maximizes the properties of the steel. This means that each shackle meets its rated strength and has required ductility, toughness, impact and fatigue properties. The requirements of your job demand this reliability and consistency. This quench and tempering process develops a tough material that reduces the risk of brittle, catastrophic failure. The shackle bow will deform if overloading occurs, giving warning before ultimate failure.</p>	<p>Ask: Are their bows and pins quenched and tempered?</p> <p>Ask: If not, are they willing to accept the increased risk of inconsistency?</p> <p>Ask: If not, why are they willing to accept inferior impact, toughness, and product deformation?</p> <p>Ask: Why do many manufacturers <u>not recommend</u> non-heat treated shackles for overhead lifting?</p> <p>Ask: Why do some recommend Quench and Tempering for alloy but not carbon grades?</p> <p>Many normalize the shackle bows. As a result, desired properties are not achieved. A few even provide bows in an "as forged" condition, resulting in the possibility of brittle failure.</p>	<p>All Crosby shackle bows and pins are quenched and tempered, which enhances their performance under cold temperatures and adverse field conditions. Crosby's Quenched and Tempered carbon shackles are recommended for all critical applications including overhead lifting. Alloy shackles are recommended when specific dimensional requirements dictate a size that requires higher working load limits. Crosby's Quenched and Tempered shackles provide the tensile strength, ductility, impact and fatigue properties that are essential if they are to perform time after time in adverse conditions. These properties assure that the inspection criteria set forth by ANSI will effectively monitor the ability of the shackles to continue in service.</p>
<p>IDENTIFICATION AND APPLICATION INFORMATION The proper application of shackles requires that the correct type and size of shackle be used. The shackle's working load limit, its size, a traceability code and the manufacturer's name should be clearly and boldly marked in the bow. Traceability of the material chemistry and properties is essential for total confidence in the product. Material chemistry should be independently verified prior to manufacturing.</p>	<p>Ask: Do they have an active traceability system used in manufacturing?</p> <p>Ask: Is the material chemistry independently verified?</p> <p>Ask: What training support is provided?</p>	<p>Crosby forges "Crosby" or "CG", the Working Load Limit, and the Product Identification Code (PIC) into each bow and pin of its full line of screw pin, round pin, and bolt type anchor and chain shackles. Seminars conducted by Crosby provide training on the proper use of shackles. Crosby training packets, supplied free to attendees of Crosby seminars, provide training materials needed to explain the proper use of shackles.</p>

* G-2160 Wide Body Shackles are metric rated at 5 to 1. G2140 shackles, 200 ton and above, are rated at 4 to 1 in short tons.



Remember, "When buying Crosby, you're buying more than product, you're buying Quality."

Crosby Value Added

- **Charpy impact properties:** Crosby's quenched and tempered shackles have enhanced impact properties for greater toughness at all temperatures. If requested at the time of order, Crosby can provide Charpy impact properties.
- **Fatigue properties:** Fatigue properties are available for 1/3 to 55 metric ton shackles. These Crosby shackles are fatigue rated to 20,000 cycles at 1-1/2 times the Working Load Limit.
- **Ductility properties:** Typical ductility properties are available for all sizes upon special request.
- **Hardness levels and material tensile strengths:** Typical values are available for all sizes of shackles, and actual values can be furnished if requested at the time of order.
- **Proof Testing:** If requested at the time of order, shackles can be furnished proof tested with certificates.
- **Mag Certification:** If requested at the time of order, shackles can be Mag inspected with certificates.
- **Certification:** Certification to World Class Standards is available upon special request at the time of order; American Bureau of Shipping, Lloyds Register of Shipping, Det Norske Veritas, American Petroleum Institute, RINA, Nuclear Regulatory Commission, and several other world wide standards.
- **Applications:** *Round Pin Shackles* can be used in tie down, towing, suspension or lifting applications where the load is strictly applied in-line. *Screw Pin Shackles* can be used in any application where a round pin shackle is used. In addition, screw pin shackles can be used for applications involving side-loading circumstances. Reduced working load limits are required for side-loading applications. *Bolt-Type Shackles* can be used in any application where round pin or screw pin shackles are used. In addition, they are recommended for permanent or long-term installations and where the load may slide on the shackle pin causing the pin to rotate.
- **Material analysis:** Crosby can provide certified material (mill) analysis for each production lot, traceable by the Product Identification Code (PIC). Crosby, through its own laboratory, verifies the analysis of each heat of steel. Crosby purchases only *special bar* forging quality steel with specific cleanliness requirements and guaranteed hardenability.
- **Field inspection:** Written instructions for visual, magnaflux, and dye penetrant inspection of shackles are available from Crosby. In addition, acceptance criteria and repair procedures for shackles are available.
- **QUIC-CHECK®:** Shackles incorporate two marking indicators forged into the shackle bow at 45° angles from vertical. These are utilized to quickly check the approximate angle of a two-legged hitch or quickly check the angle of a single leg hitch when the shackle pin is secured and the pull of the load is off vertical or side loaded, thus requiring a reduction in the working load limit of the shackle.

G-209 S-209
Screw pin anchor shackles meet the performance requirements of Federal Specification RR-C-271D Type IVA, Grade A, Class 2, except for those provisions required of the contractor.



G-213 S-213
Round pin anchor shackles meet the performance requirements of Federal Specification RR-C-271D Type IVA, Grade A, Class 1, except for those provisions required of the contractor.



G-2130 S-2130
Bolt-type anchor shackles meet the performance requirements of Federal Specification RR-C-271D Type IVA, Grade A, Class 3, except for those provisions required of the contractor.



G-210 S-210
Screw pin chain shackles meet the performance requirements of Federal Specification RR-C-271D Type IVB, Grade A, Class 2, except for those provisions required of the contractor.



G-215 S-215
Round pin chain shackles meet the performance requirements of Federal Specification RR-C-271D Type IVB, Grade A, Class 1, except for those provisions required of the contractor.



G-2150 S-2150
Bolt-type chain shackles meet the performance requirements of Federal Specification RR-C-271D Type IVB, Grade A, Class 3, except for those provisions required of the contractor.



Crosby® Round Pin Shackles

Load Rated

Fatigue Rated



ROUND PIN ANCHOR SHACKLES



G-213 S-213

Round pin anchor shackles meet the performance requirements of Federal Specification RR-C-271D Type IVA, Grade A, Class 1, except for those provisions required of the contractor.

- Shackles are Quenched and Tempered and can meet DNV impact requirements of 42 joules at -20°C.
- Working Load Limit permanently shown on every shackle.
- Forged - Quenched and Tempered, with alloy pins.
- Capacities 1/2 thru 35 metric tons.
- Look for the Red Pin® . . . the mark of genuine Crosby quality.
- Shackles can be furnished proof tested with certificates to designated standards, such as ABS, DNV, Lloyds, or other certification. Charges for proof testing and certification available when requested at the time of order.
- Hot Dip galvanized.
- Fatigue rated.

ROUND PIN CHAIN SHACKLES



G-215 S-215

Round pin chain shackles meet the performance requirements of Federal Specification RR-C-271D Type IVB, Grade A, Class 1, except for those provisions required of the contractor.

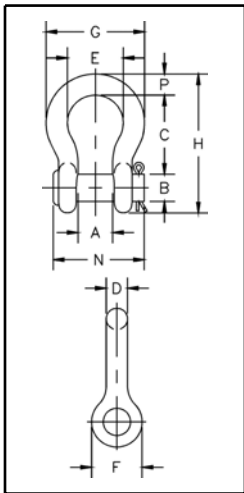

G-213 S-213

Nominal Size (in.)	Working Load Limit (t) *	Stock No.		Weight Each (kg.)	Dimensions (mm)											Tolerance +/-	
		G-213	S-213		A	B	C	D	E	F	G	H	N	P	C	A	
1/4	1/2	1018017	1018026	.06	11.9	7.85	28.7	6.35	19.8	15.5	32.5	46.7	34.0	6.35	1.50	1.50	
5/16	3/4	1018035	1018044	.08	13.5	9.65	31.0	7.85	21.3	19.1	37.3	53.0	40.4	7.85	1.50	1.50	
3/8	1	1018053	1018062	.13	16.8	11.2	36.6	9.65	26.2	23.1	45.2	63.0	47.2	9.65	3.30	1.50	
7/16	1-1/2	1018071	1018080	.17	19.1	12.7	42.9	11.2	29.5	26.9	51.5	74.0	54.0	11.2	3.30	1.50	
1/2	2	1018099	1018106	.32	20.6	16.0	47.8	12.7	33.3	30.2	58.5	83.5	60.5	12.7	3.30	1.50	
5/8	3-1/4	1018115	1018124	.68	26.9	19.1	60.5	16.0	42.9	38.1	74.5	106	74.0	17.5	3.30	1.50	
3/4	4-3/4	1018133	1018142	1.05	31.8	22.4	71.5	19.1	51.0	46.0	89.0	126	87.0	20.6	6.35	1.50	
7/8	6-1/2	1018151	1018160	1.58	36.6	25.4	84.0	22.4	58.0	53.0	102	148	96.5	24.6	6.35	1.50	
1	8-1/2	1018179	1018188	2.27	42.9	28.7	95.5	25.4	68.5	60.5	119	167	115	26.9	6.35	1.50	
1-1/8	9-1/2	1018197	1018204	3.16	46.0	31.8	108	29.5	74.0	68.5	131	190	130	31.8	6.35	1.50	
1-1/4	12	1018213	1018222	4.42	51.5	35.1	119	32.8	82.5	76.0	146	210	140	35.1	6.35	1.50	
1-3/8	13-1/2	1018231	1018240	6.01	57.0	38.1	133	36.1	92.0	84.0	162	233	156	38.1	6.35	3.30	
1-1/2	17	1018259	1018268	7.82	60.5	41.4	146	39.1	98.5	92.0	175	254	165	41.1	6.35	3.30	
1-3/4	25	1018277	1018286	13.4	73.0	51.0	178	46.7	127	106	225	313	197	57.0	6.35	3.30	
2	35	1018295	1018302	20.8	82.5	57.0	197	53.0	146	122	253	348	222	61.0	6.35	3.30	

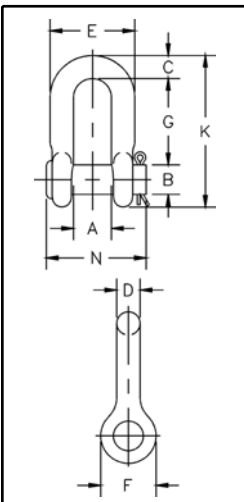

G-215 S-215

Nominal Size (in.)	Working Load Limit (t) *	Stock No.		Weight Each (kg.)	Dimensions (mm)											Tolerance +/-	
		G-215	S-215		A	B	C	D	E	F	G	K	N	G	A		
1/4	1/2	1018810	1018829	.05	11.9	7.85	6.35	6.35	24.6	15.5	22.4	40.4	34.0	1.50	1.50		
5/16	3/4	1018838	1018847	.08	13.5	9.65	7.85	7.85	29.5	19.1	26.2	48.5	40.4	1.50	1.50		
3/8	1	1018856	1018865	.11	16.8	11.2	9.65	9.65	35.8	23.1	31.8	58.5	47.2	3.30	1.50		
7/16	1-1/2	1018874	1018883	.18	19.1	12.7	11.2	11.2	41.4	26.9	36.6	67.5	54.0	3.30	1.50		
1/2	2	1018892	1018909	.23	20.6	16.0	12.7	12.7	46.0	30.2	41.4	77.0	60.5	3.30	1.50		
5/8	3-1/4	1018918	1018927	.55	26.9	19.1	15.7	16.0	58.5	38.1	51.0	95.5	74.0	3.30	1.50		
3/4	4-3/4	1018936	1018945	.91	31.8	22.4	20.6	19.1	70.0	46.0	60.5	115	87.0	6.35	1.50		
7/8	6-1/2	1018954	1018963	1.49	36.6	25.4	24.6	22.4	81.0	53.0	71.5	135	96.5	6.35	1.50		
1	8-1/2	1018972	1018981	2.15	42.9	28.7	25.4	25.4	93.5	60.5	81.0	151	115	6.35	1.50		
1-1/8	9-1/2	1018990	1019007	2.86	46.0	31.8	31.8	28.7	103	68.5	91.0	172	130	6.35	1.50		
1-1/4	12	1019016	1019025	4.08	51.5	35.1	35.1	31.8	115	76.0	100	191	140	6.35	3.30		
1-3/8	13-1/2	1019034	1019043	5.44	57.0	38.1	38.1	35.1	127	84.0	111	210	156	6.35	3.30		
1-1/2	17	1019052	1019061	7.33	60.5	41.4	41.1	38.1	137	92.0	122	230	165	6.35	3.30		
1-3/4	25	1019070	1019089	13.6	73.0	51.0	54.0	44.5	162	106	146	279	197	6.35	3.30		
2	35	1019098	1019105	19.6	82.5	57.0	51.0	51.0	184	122	172	312	222	6.35	3.30		

* NOTE: Maximum Proof Load is 2.0 times the Working Load Limit. Minimum Ultimate Strength is 6 times the Working Load Limit.

Round Pin shackles are not suitable for side loading applications.

Crosby® Screw Pin Shackles

Load Rated

Fatigue Rated



SCREW PIN ANCHOR SHACKLES



G-209 S-209

Screw pin anchor shackles meet the performance requirements of Federal Specification RR-C-271D Type IVA, Grade A, Class 2, except for those provisions required of the contractor.

- Shackles are Quenched and Tempered and can meet DNV impact requirements of 42 joules at -20°C..
- Working Load Limit permanently shown on every shackle.
- Forged - Quenched and Tempered, with alloy pins.
- Capacities 1/3 thru 55 metric tons.
- Look for the Red Pin® . . . the mark of genuine Crosby quality.
- Shackles can be furnished proof tested with certificates to designated standards, such as ABS, DNV, Lloyds, or other certification. Charges for proof testing and certification available when requested at the time of order.
- Hot Dip galvanized.
- Fatigue rated.

SCREW PIN CHAIN SHACKLES



G-210 S-210

Screw pin chain shackles meet the performance requirements of Federal Specification RR-C-271D, Type IVB, Grade A, Class 2, except for those provisions required of the contractor.

Shackles

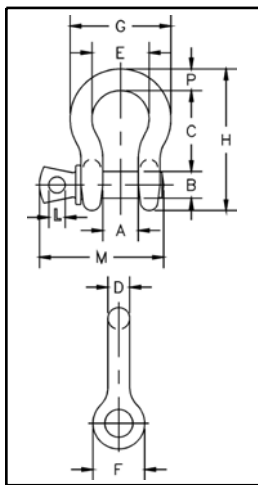

G-209 S-209

Nominal Size (in.)	Working Load Limit (t) *	Stock No.		Weight Each (kg)	Dimensions (mm)													Tolerance +/-	
		G-209	S-209		A	B	C	D	E	F	G	H	L	M	P	C	A		
3/16	1/3	1018357	-	.03	9.65	6.35	22.4	4.85	15.2	14.2	24.9	37.3	4.06	28.4	4.85	1.50	1.50		
1/4	1/2	1018375	1018384	.05	11.9	7.85	28.7	6.35	19.8	15.5	32.5	46.7	4.85	35.1	6.35	1.50	1.50		
5/16	3/4	1018393	1018400	.09	13.5	9.65	31.0	7.85	21.3	19.1	37.3	53.0	5.60	42.2	7.85	3.30	1.50		
3/8	1	1018419	1018428	.14	16.8	11.2	36.6	9.65	26.2	23.1	45.2	63.0	6.35	51.5	9.65	3.30	1.50		
7/16	1-1/2	1018437	1018446	.17	19.1	12.7	42.9	11.2	29.5	26.9	51.5	74.0	7.85	60.5	11.2	3.30	1.50		
1/2	2	1018455	1018464	.33	20.6	16.0	47.8	12.7	33.3	30.2	58.5	83.5	9.65	68.5	12.7	3.30	1.50		
5/8	3-1/4	1018473	1018482	.62	26.9	19.1	60.5	16.0	42.9	38.1	74.5	106	11.2	85.0	17.5	6.35	1.50		
3/4	4-3/4	1018491	1018507	1.07	31.8	22.4	71.5	19.1	51.0	46.0	89.0	126	12.7	101	20.6	6.35	1.50		
7/8	6-1/2	1018516	1018525	1.64	36.6	25.4	84.0	22.4	58.0	53.0	102	148	12.7	114	24.6	6.35	1.50		
1	8-1/2	1018534	1018543	2.28	42.9	28.7	95.5	25.4	68.5	60.5	119	167	14.2	129	26.9	6.35	1.50		
1-1/8	9-1/2	1018552	1018561	3.36	46.0	31.8	108	29.5	74.0	68.5	131	190	16.0	142	31.8	6.35	1.50		
1-1/4	12	1018570	1018589	4.31	51.5	35.1	119	32.8	82.5	76.0	146	210	17.5	156	35.1	6.35	1.50		
1-3/8	13-1/2	1018598	1018605	6.14	57.0	38.1	133	36.1	92.0	84.0	162	233	19.1	174	38.1	6.35	3.30		
1-1/2	17	1018614	1018623	7.80	60.5	41.4	146	39.1	98.5	92.0	175	254	20.6	187	41.1	6.35	3.30		
1-3/4	25	1018632	1018641	12.6	73.0	51.0	178	46.7	127	106	225	313	25.4	231	57.0	6.35	3.30		
2	35	1018650	1018669	20.4	82.5	57.0	197	53.0	146	122	253	348	31.0	263	61.0	6.35	3.30		
2-1/2	55	1018678	1018687	38.9	105	70.0	267	69.0	184	145	327	453	35.1	330	79.5	6.35	6.35		

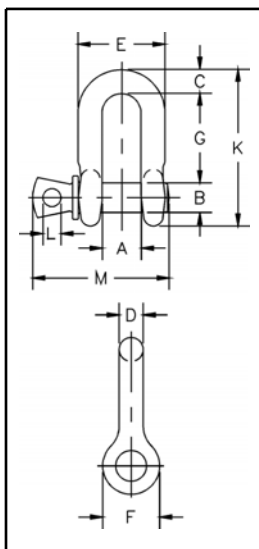

G-210 S-210

Nominal Size (in.)	Working Load Limit (t) *	Stock No.		Weight Each (kg)	Dimensions (mm)													Tolerance +/-	
		G-210	S-210		A	B	C	D	E	F	G	K	L	M	G	A			
1/4	1/2	1019150	1019169	.05	11.9	7.85	6.35	6.35	24.6	15.5	22.4	40.4	4.85	35.1	1.50	1.50			
5/16	3/4	1019178	1019187	.08	13.5	9.65	7.85	7.85	29.5	19.1	26.2	48.5	5.60	42.2	1.50	1.50			
3/8	1	1019196	1019203	.13	16.8	11.2	9.65	9.65	35.8	23.1	31.8	58.5	6.35	51.5	3.30	1.50			
7/16	1-1/2	1019212	1019221	.20	19.1	12.7	11.2	11.2	41.4	26.9	36.6	67.5	7.85	60.5	3.30	1.50			
1/2	2	1019230	1019249	.27	20.6	16.0	12.7	12.7	46.0	30.2	41.4	77.0	9.65	68.5	3.30	1.50			
5/8	3-1/4	1019258	1019267	.57	26.9	19.1	15.7	16.0	58.5	38.1	51.0	95.5	11.2	85.0	3.30	1.50			
3/4	4-3/4	1019276	1019285	1.20	31.8	22.4	20.6	19.1	70.0	46.0	60.5	115	12.7	101	6.35	1.50			
7/8	6-1/2	1019294	1019301	1.43	36.6	25.4	24.6	22.4	81.0	53.0	71.5	136	12.7	114	6.35	1.50			
1	8-1/2	1019310	1019329	2.15	42.9	28.7	25.4	25.4	93.5	60.5	81.0	151	14.2	129	6.35	1.50			
1-1/8	9-1/2	1019338	1019347	3.06	46.0	31.8	31.8	28.7	103	68.5	91.0	172	16.0	142	6.35	1.50			
1-1/4	12	1019356	1019365	4.11	51.5	35.1	35.1	31.8	115	76.0	100	191	17.5	156	6.35	3.30			
1-3/8	13-1/2	1019374	1019383	5.28	57.0	38.1	38.1	35.1	127	84.0	111	210	19.1	174	6.35	3.30			
1-1/2	17	1019392	1019409	7.23	60.5	41.4	41.1	38.1	137	92.0	122	230	20.6	187	6.35	3.30			
1-3/4	25	1019418	1019427	12.1	73.0	51.0	54.0	44.5	162	106	146	279	25.4	231	6.35	3.30			
2	35	1019436	1019445	19.2	82.5	57.0	51.0	51.0	184	122	172	312	31.0	263	6.35	3.30			
2-1/2	55	1019454	1019463	32.5	105	70.0	66.5	66.5	238	145	203	377	35.1	330	6.35	6.35			

* NOTE: Maximum Proof Load is 2.0 times the Working Load Limit. Minimum Ultimate Strength is 6 times the Working Load Limit. For Working Load Limit reduction due to side loading applications, see page 68.

Crosby® Alloy Screw Pin Shackles

Load Rated™



G-209A



- Working Load Limit permanently shown on every shackle.
- Forged Alloy Steel- Quenched and Tempered, with alloy pins.
- Capacities 2 thru 21 tons.
- Shackles can be furnished proof tested with certificates to designated standards, such as ABS, DNV, Lloyds, or other certification. Charges for proof testing and certification available when requested at the time of order.
- Hot Dip Galvanized.

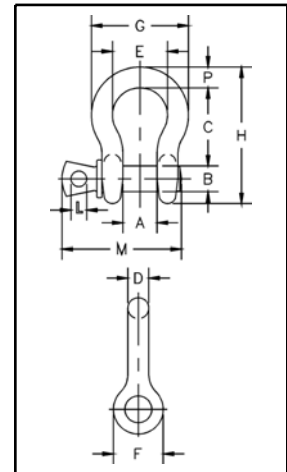

Screw pin anchor shackles meet the performance requirements of Federal Specification RR-C-271D Type IVA, Grade B, Class 2, except for those provisions required of the contractor.

G-209A

Crosby® Alloy Screw Pin Shackles

Nominal Size (in.)	Working Load Limit (t)*	G-209-A Stock No.	Weight Each (kg)	Dimensions (mm)											Tolerance +/-	
				A	B	C	D	E	F	G	H	L	M	P	C	A
3/8	2	1017450	.14	16.8	11.2	36.6	9.65	26.2	23.1	45.2	63.5	6.35	51.5	9.65	3.30	1.50
7/16	2-2/3	1017472	.17	19.1	12.7	42.9	11.2	29.5	26.9	51.5	74.0	7.85	60.5	11.2	3.30	1.50
1/2	3-1/3	1017494	.29	20.6	16.0	47.8	12.7	23.3	30.2	58.5	83.5	9.65	68.5	12.7	3.30	1.50
5/8	5	1017516	.63	26.9	19.1	60.5	16.0	42.9	38.1	74.5	106	11.2	85.0	17.5	3.30	1.50
3/4	7	1017538	1.02	31.8	22.4	71.5	19.1	51.0	46.0	89.0	126	12.7	101	20.6	6.35	1.50
7/8	9-1/2	1017560	1.53	36.6	25.4	84.0	22.4	58.0	53.0	102	148	12.7	114	24.6	6.35	1.50
1	12-1/2	1017582	2.41	42.9	28.7	95.5	25.4	68.5	60.5	119	167	14.2	129	26.9	6.35	1.50
1-1/8	15	1017604	3.09	46.0	31.8	108	29.5	74.0	68.5	131	190	16.0	142	31.8	6.35	1.50
1-1/4	18	1017626	4.31	51.5	35.1	119	32.8	82.5	76.0	146	210	17.5	156	35.1	6.35	1.50
1-3/8	21	1017648	6.01	57.0	38.1	133	36.1	92.0	84.0	162	233	19.1	174	38.1	6.35	3.30

* Maximum Proof Load is 2 times the Working Load Limit (metric tons) and 2.2 times the Working Load Limit (short tons). Minimum Ultimate Strength is 4 times the Working Load Limit. For Working Load Limit reduction due to side loading applications, see page 68.

Crosby® Bolt Type Shackles

Load Rated

Fatigue Rated



BOLT TYPE ANCHOR SHACKLES



G-2130 S-2130

Bolt Type Anchor shackles with thin head bolt - nut with cotter pin. Meets the performance requirements of Federal Specification RR-C-271D Type IVA, Grade A, Class 3, except for those provisions required of the contractor.

- Working Load Limit permanently shown on every shackle. Capacities 1/3 thru 150 metric tons.
- Forged — Quenched and Tempered, with alloy pins.
- Look for the Red Pin® . . . the mark of genuine Crosby quality.
- Shackles 55 metric tons and smaller can be furnished proof tested with certificates to designated standards, such as ABS, DNV, Lloyds, or other certification.
- Shackles 85 metric tons and larger can be provided as follows.
 - Non Destructive Tested
 - Serialized Pin and Bow
 - Material Certification (Chemical) Certification must be requested at time of order.
- Hot Dip galvanized or Self Colored.
- Fatigue rated.

BOLT TYPE CHAIN SHACKLES



G-2150 S-2150

Bolt Type Chain shackles. Thin hex head bolt - nut with cotter pin. Meets the performance requirements of Federal Specification RR-C271D Type IVB, Grade A, Class 3, except for those provisions required of the contractor.

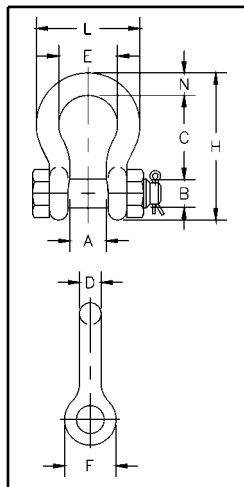

G-2130 S-2130

Nominal Size (in.)	Working Load Limit (t) *	Stock No.		Weight Each (kg)	Dimensions (mm)										Tolerance +/-	
		G-2130	S-2130		A	B	C	D	E	F	H	L	N	C	A	
3/16	1/3 ‡	1019464	-	.08	9.65	6.35	22.4	4.85	15.2	14.2	37.3	24.9	4.85	1.50	1.50	
1/4	1/2	1019466	-	.05	11.9	7.85	28.7	6.35	19.8	15.5	46.7	32.5	6.35	1.50	1.50	
5/16	3/4	1019468	-	.10	13.5	9.65	31.0	7.85	21.3	19.1	53.0	37.3	7.85	3.30	1.50	
3/8	1	1019470	-	.15	16.8	11.2	36.6	9.65	26.2	23.1	63.0	45.2	9.65	3.30	1.50	
7/16	1-1/2	1019471	-	.22	19.1	12.7	42.9	11.2	29.5	26.9	74.0	51.5	11.2	3.30	1.50	
1/2	2	1019472	1019481	.36	20.6	16.0	47.8	12.7	33.3	30.2	83.5	58.5	12.7	3.30	1.50	
5/8	3-1/4	1019490	1019506	.76	26.9	19.1	60.5	16.0	42.9	38.1	106	74.5	17.5	6.35	1.50	
3/4	4-3/4	1019515	1019524	1.23	31.8	22.4	71.5	19.1	51.0	46.0	126	89.0	20.6	6.35	1.50	
7/8	6-1/2	1019533	1019542	1.79	36.6	25.4	84.0	22.4	58.0	53.0	148	102	24.6	6.35	1.50	
1	8-1/2	1019551	1019560	2.57	42.9	28.7	95.5	25.4	68.5	60.5	167	119	26.9	6.35	1.50	
1-1/8	9-1/2	1019579	1019588	3.75	46.0	31.8	108	28.7	74.0	68.5	190	131	31.8	6.35	1.50	
1-1/4	12	1019597	1019604	5.31	51.5	35.1	119	31.8	82.5	76.0	210	146	35.1	6.35	1.50	
1-3/8	13-1/2	1019613	1019622	7.18	57.0	38.1	133	35.1	92.0	84.0	233	162	38.1	6.35	3.30	
1-1/2	17	1019631	1019640	9.43	60.5	41.4	146	38.1	98.5	92.0	254	175	41.1	6.35	3.30	
1-3/4	25	1019659	1019668	15.4	73.0	51.0	178	44.5	127	106	313	225	57.0	6.35	3.30	
2	35	1019677	1019686	23.7	82.5	57.0	197	51.0	146	122	348	253	61.0	6.35	3.30	
2-1/2	55	1019695	1019702	44.6	105	70.0	267	66.5	184	145	453	327	79.5	6.35	6.35	
3	† 85	1019711	-	70	127	82.5	330	76.0	200	165	546	365	92.0	6.35	6.35	
3-1/2	† 120 ‡	1019739	-	120	133	95.5	372	92.0	229	203	626	419	105	6.35	6.35	
4	† 150 ‡	1019757	-	153	140	108	368	104	254	229	653	468	116	6.35	6.35	

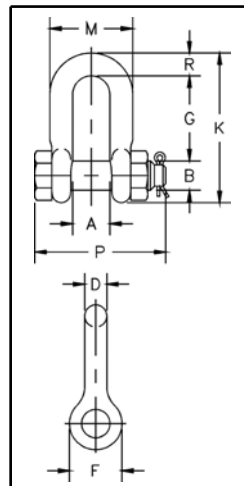

G-2150 S-2150

Nominal Size (in.)	Working Load Limit (t) *	Stock No.		Weight Each (kg)	Dimensions (mm)										Tolerance +/-	
		G-2150	S-2150		A	B	D	F	G	K	M	P	R	G	A	
1/4	1/2	1019768	-	.06	11.9	7.85	6.35	15.5	19.1	40.4	24.6	39.6	6.35	1.50	1.50	
5/16	3/4	1019770	-	.10	13.5	9.65	7.85	19.1	25.4	48.5	29.5	46.2	7.85	1.50	1.50	
3/8	1	1019772	-	.15	16.8	11.2	9.65	23.1	31.0	58.5	35.8	55.0	9.65	3.30	1.50	
7/16	1-1/2	1019774	-	.22	19.1	12.7	11.2	26.9	36.1	67.5	41.1	63.5	11.2	3.30	1.50	
1/2	2	1019775	1019784	.34	20.6	16.0	12.7	30.2	41.4	77.0	46.0	71.0	12.7	3.30	1.50	
5/8	3-1/4	1019793	1019800	.67	26.9	19.1	16.0	38.1	51.0	95.5	58.5	89.5	16.0	3.30	1.50	
3/4	4-3/4	1019819	1019828	1.14	31.8	22.4	19.1	46.0	60.5	115	70.0	103	20.6	6.35	1.50	
7/8	6-1/2	1019837	1019846	1.74	36.6	25.4	22.4	53.0	71.5	135	81.0	120	24.6	6.35	1.50	
1	8-1/2	1019855	1019864	2.52	42.9	28.7	25.4	60.5	81.0	151	93.5	135	25.4	6.35	1.50	
1-1/8	9-1/2	1019873	1019882	3.45	46.0	31.8	28.7	68.5	91.0	172	103	150	31.8	6.35	1.50	
1-1/4	12	1019891	1019908	4.90	51.5	35.1	31.8	76.0	100	191	115	165	35.1	6.35	1.50	
1-3/8	13-1/2	1019917	1019926	6.24	57.0	38.1	35.1	84.0	111	210	127	183	38.1	6.35	3.30	
1-1/2	17	1019935	1019944	8.39	60.5	41.4	38.1	92.0	122	230	137	196	41.1	6.35	3.30	
1-3/4	25	1019953	1019962	14.2	73.0	51.0	44.5	106	146	279	162	230	54.0	6.35	3.30	
2	35	1019971	1019980	21.2	82.5	57.0	51.0	122	172	312	184	264	51.0	6.35	3.30	
2-1/2	55	1019999	1020004	38.6	105	70.0	66.5	145	203	377	238	344	66.5	6.35	6.35	
3	† 85	1020013	-	56	127	82.5	76.0	165	216	429	279	419	89.0	6.35	6.35	

* NOTE: Maximum Proof Load is 2.0 times the Working Load Limit. Minimum Ultimate Strength is 6 times the Working Load Limit. For Working Load Limit reduction due to side loading applications, see page 68.

† Individually Proof Tested with certification.

‡ Furnished in Anchor style only and furnished with Round Head Bolts with welded handles.

Shackles

Crosby® Alloy Bolt Type Shackles

Load Rated™



**G-2140 / S-2140
ALLOY
BOLT TYPE
ANCHOR SHACKLES**



G-2140 meets the performance requirements of Federal Specification RR-C-271D, Type IVA, Grade B, Class 3, except for those provisions required of the contractor.

- Shackles are Quenched and Tempered and can meet DNV impact requirements of 42 joules at -20°C.
- Working Load Limit is permanently shown on every shackle.
- Alloy bows, Alloy bolts.
- Quenched and Tempered.
- All sizes are individually proof tested to 2.0 times the Working Load Limit.
- Shackles 200 metric tons and larger are provided as follows.
 - Non Destructive Tested
 - Serialized Pin and Bow
 - Material Certification (Chemical)
- Certification must be requested at time of order.
- Forged Alloy Steel 30 thru 175 metric tons. Cast Alloy Steel 200 thru 400 metric tons.
- Pins are galvanized and painted red.

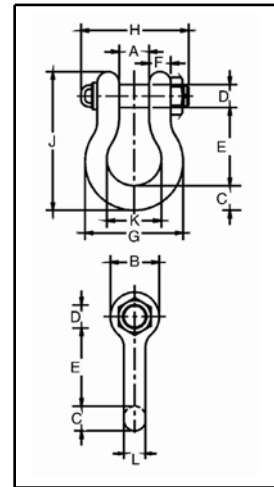

NOTICE: All 2140 shackles 200 tons and larger are magnetic particle inspected. Certification available on special request.

Nominal Shackle Size (in.)	Working Load Limit (t)*	Stock No.		Weight Each (kg)	Dimensions (mm)											Tolerance +/-	
		G-2140	S-2140		A	B	C	D	E	F	G	H	J	K	L	A	E
1-1/2	30	1021110	1021129	9.43	60.5	92.0	41.1	41.4	146	35.3	175	197	254	98.5	39.1	3.30	6.35
1-3/4	40	1021138	1021147	15.4	73.0	106	57.0	51.0	178	44.5	225	230	313	127	46.7	3.30	6.35
2	55	1021156	1021165	23.6	82.5	122	61.0	57.0	197	51.0	253	264	348	146	53.0	3.30	6.35
2-1/2	85	1021174	1021183	43.5	105	145	79.0	70.0	267	66.5	327	344	453	184	69.0	6.35	6.35
3	120	1021192	-	81	127	165	92.0	82.5	330	76.0	365	419	546	200	79.0	6.35	6.35
3-1/2	† 150	1021218	-	120	133	203	105	95.5	372	95.5	419	483	625	229	92.0	6.35	6.35
4	† 175	1021236	-	153	140	229	116	108	368	102	468	502	626	254	104	6.35	6.35
4-3/4**	† 200	1021414	-	204	184	267	152	121	397	95.5	533	521	743	279	114	6.35	6.35
5**	† 250	1021432	-	272	216	305	165	127	508	98.5	622	558	889	330	114	6.35	6.35
6**	† 300	1021450	-	352	213	305	172	152	495	121	635	618	895	330	127	6.35	6.35
7**	† 400	1021478	-	500	210	356	184	178	572	165	660	710	1022	330	152	6.35	6.35

* Note Maximum Proof Load is 2.0 times the Working Load Limit. Minimum Ultimate Load is 4 times the Working Load Limit on 200 thru 400 metric Tons. For sizes 30 thru 175 metric Tons, Minimum Ultimate Load is 5.4 times the Working Load Limit.

** Cast Alloy Steel.

† Furnished with Round Head Bolts with welded handle.

For Working Load Limit reduction due to side loading applications, see page 68.

Crosby® Wide Body Shackles

Load Rated



**G-2160
"WIDE BODY"
SHACKLES**



Patented

- Greatly improves wearability of wire rope slings.
- Can be used to connect HIGHSTRENGTH Synthetic Web Slings, HIGHSTRENGTH Synthetic Round Slings or Wire Rope Slings.
- Increase in shackle bow radius provides minimum 58% gain in sling bearing surface and eliminates need for a thimble.
- Increases usable sling strength minimum of 15%.
- Pin is non-rotating, with weld on handles for easier use (300t and larger).
- All ratings are in metric tons, embossed on side of bow.
- Forged alloy steel from 30 through 300 metric tons.
- Cast alloy steel from 400 through 1000 metric tons.
- Sizes 400 tons and larger are tested to 1.33 times Working Load Limit.
- Sizes 300 tons and smaller are proof tested to 2 times the Working Load Limit.
- All 2160 shackles are individually proof tested, Crosby certification available at time of order. Shackles requiring ABS, DNV, Lloyds and other certifications are available upon special request and must be specified at time of order.
- Shackles are produced in accordance with certified lifting appliance requirements.
 - Non Destructive Testing
 - Serialization / Identification
 - Material Testing (Physical / Chemical / Charpy)
 - Proof Testing
- All sizes Quenched and Tempered for maximum strength.
- Bows and pins are furnished Dimetcoated. All Pins are Dimetcoated then painted red.
- Type Approval and certification in accordance with DNV specifications 2.7-1 Offshore Containers and DNV rules for Lifting Appliances-Loose Gear.

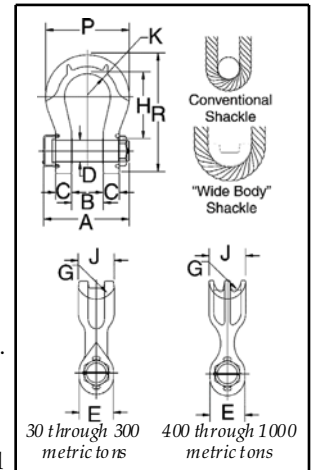

Shackles

NOTICE: All G-2160 shackles are magnetic particle inspected.

Working Load Limit (t)*	G-2160 Stock No.	Weight Each (kg)	Dimensions (mm)										
			A	B +/- 6.35	C	D +/- .5	E	G	H	J	K	P	R
†30	1021575	11.3	197	60.5	35.1	41.4	90.4	51.0	165	79.5	63.5	232	279
†40	1021584	15.9	230	73.2	44.5	51.0	102	58.7	205	95.3	76.2	270	346
†55	1021593	32.2	264	82.5	51.0	57.4	118	66.8	238	114	88.9	327	394
†75	1021290	45	346	105	54.0	70.0	121	64.0	290	120	92.5	313	465
†125	1021307	73	400	130	65.0	80.0	145	80.0	365	150	110	380	576
†200	1021316	227	508	150	85.0	105	185	110	480	205	137	495	757
†300	1021325	368	591	185	102	133	235	140	600	265	160	601	950
††400	1021334	472	715	220	131	160	280	160	575	320	185	690	985
††500	1021343	625	809	250	142	180	318	170	630	340	225	790	1085
††600	1021352	831	913	275	153	200	350	185	700	370	247	865	1200
††700	1021361	1109	992	300	167	215	376	200	735	400	270	940	1275
††800	1021254	1368	986	325	183	230	400	210	750	420	277	975	1323
††900	1021389	1559	1050	350	198	250	430	220	757	440	293	1025	1373
††1000	1021370	1824	1176	380	212	270	450	230	760	460	308	1075	1405

* Ultimate Load is 5 times the Working Load Limit.
 † Forged Alloy Steel. Proof Load is 2 times the Working Load Limit.
 †† Cast Alloy Steel. Proof Load is 1.33 times the Working Load Limit.

Crosby® COLD-TUFF® Shackles

Fatigue Rated



G-2130CT
/
G-2140CT



- Working Load Limit permanently shown on every shackle.
- Forged - Quenched and Tempered, with alloy bolt.
 - G-2130CT - Carbon Steel
 - G-2140CT - Alloy Steel
- Type Approval and certification in accordance with DNV Specification 2.7-1 Offshore Containers and DNV rules for Lifting Appliances - Loose Gear.
- Fatigue Rated (G-2130CT only).
- All sizes are individually proof tested to 2.0 times the Working Load Limit.
- Finish is Inorganic Zinc Primer or Hot Dipped Galvanized.
- Individually Serialized with Certification.
- Bow and Bolt are Certified to meet Charpy impact testing of 42 J min. ave. at -20°C.
- Individually Magnetic Particle Inspected with certification.

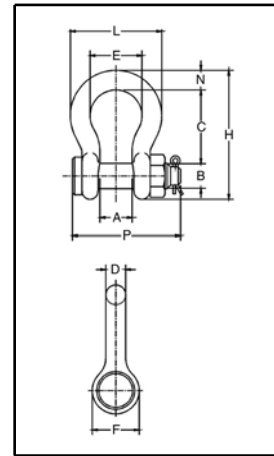

G-2130 CT

- Bolt Type Anchor shackle with thin head bolt - nut with cotter pin. Meets the performance requirements of Federal Specification RR-C271D Type IVA, Grade A, Class 3, except for those provisions required of the contractor.

Nominal Shackle Size (in.)	Working Load Limit (t)*	G-2130 CT Stock No.	Weight Each (kg)	Dimensions (mm)										Tolerance +/-	
				A	B	C	D	E	F	H	L	N	P	A	C
3/4	4-3/4	1260568	1.23	31.8	22.4	71.5	19.1	51.0	46.0	126	89.0	20.6	108	1.50	6.35
7/8	6-1/2	1260577	1.76	36.6	25.4	84.0	22.4	58.0	53.0	148	102	24.6	120	1.50	6.35
1	8-1/2	1260586	2.57	42.9	28.7	95.5	26.2	68.5	60.5	167	119	26.9	137	1.50	6.35
1-1/8	9-1/2	1260595	3.75	46.0	31.8	108	28.7	74.0	68.5	190	131	31.8	150	1.50	6.35
1-1/4	12	1260604	5.31	51.5	35.1	119	32.8	82.5	76.0	210	146	35.1	168	1.50	6.35
1-3/8	13-1/2	1260613	6.85	57.0	38.1	133	35.1	92.0	84.0	233	162	38.1	183	3.30	6.35
1-1/2	17	1260622	9.43	60.5	41.4	146	39.1	98.5	92.0	254	175	41.1	195	3.30	6.35
1-3/4	25	1260633	15.4	73.0	51.0	178	46.7	127	106	313	225	57.0	233	3.30	6.35

* NOTE: For Working Load Limit reduction due to side loading applications, see page 68.

G-2140 CT

- G-2140 meets the performance requirements of Federal Specifications RR-C-271D, Type IV A, Grade B, Class 3 except for those provisions required of the contractor.

Nominal Shackle Size (in.)	Working Load Limit (t)*	G-2140 CT Stock No.	Weight Each (kg)	Dimensions (mm)										Tolerance +/-	
				A	B	C	D	E	F	H	L	N	P	A	C
1-1/2	30	1260801	9.43	60.5	41.4	146	39.1	98.5	92.0	254	175	41.1	195	3.30	6.35
1-3/4	40	1260812	15.4	73.0	51.0	178	46.7	127	106	313	225	57.0	233	3.30	6.35
2	55	1260823	23.6	82.5	57.0	197	53.0	146	122	348	253	61.0	258	3.30	6.35
2-1/2	85	1260834	43.5	105	70.0	267	69.0	184	145	453	327	79.0	329	6.35	6.35
3	120	1260843	81	127	82.5	330	79.0	200	165	546	365	92.0	419	6.35	6.35
3-1/2	† 150	1260852	120	133	95.5	372	92.0	229	203	625	419	105	483	6.35	6.35
4	† 175	1260861	153	140	108	368	104	254	229	626	468	116	502	6.35	6.35
4 3/4	† 200	1260870	204	184	121	397	114	279	267	743	533	152	521	6.35	6.35
5	† 250	1260889	272	216	127	508	114	330	305	889	622	165	558	6.35	6.35

* NOTE: Maximum Proof Load is 2.0 times the Working Load Limit.

4-3/4t - 175t, Minimum Ultimate Load is 5.4 times the Working Load Limit.

200t and larger, Minimum Ultimate Load is 4 times the Working Load Limit.

† Furnished with Round Head Bolts with welded handle.

Crosby® Shackles

APPLICATION INFORMATION



G/S - 213



G/S - 215

Round Pin Shackles can be used in tie down, towing, suspension or lifting applications where the load is strictly applied in-line.



G-209 A



G/S-209



G/S-210

Screw Pin Shackles can be used in any application where a round pin shackle is used. In addition, screw pin shackles can be used for applications involving side-loading circumstances. Reduced working load limits are required for side-loading applications. While in service, do not allow the screw pin to be rotated by a live line, such as a choker application.



G/S - 2130



G/S - 2150



G/S - 2140



G - 2160

Bolt-Type Shackles can be used in any applications where round pin or screw pin shackles are used. In addition, they are recommended for permanent or long term installations and where the load may slide on the shackle pin causing the pin to rotate.

QUIC-CHECK® INFORMATION



G-2130

All Crosby Shackles, except for G-2160's incorporate markings forged into the product which address an easy QUIC-CHECK® feature. Angle indicators are forged into the shackle bow at 45° angles from vertical. These are utilized to quickly check the approximate angle of a two-legged hitch or quickly check the angle of a single leg hitch when the shackle pin is secured and the pull of the load is off vertical or side loaded, thus requiring a reduction in the working load limit of the shackle.

Crosby® Shackles

Angle loads must be applied in the plane of the bow.

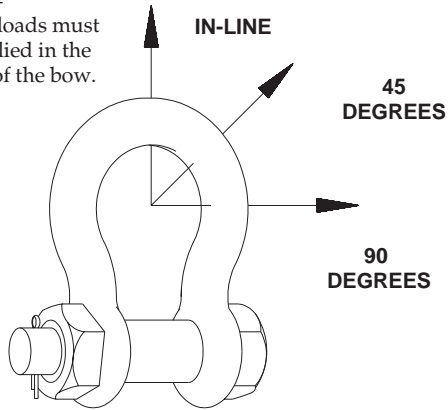

Side Loading Reduction Chart For Screw Pin and Bolt Type Shackles Only †	
Angle of Side Load from Vertical In-Line of shackle	Adjusted Working Load Limit
0° In-Line *	100% of Rated Working Load Limit
45° from In-Line *	70% of Rated Working Load Limit
90° from In-Line *	50% of Rated Working Load Limit

* In-Line load is applied perpendicular to pin.
† DO NOT SIDE LOAD ROUND PIN SHACKLES

Never Exceed 120° included angle.
Use Bolt Type and Screw Pin Shackles ONLY.

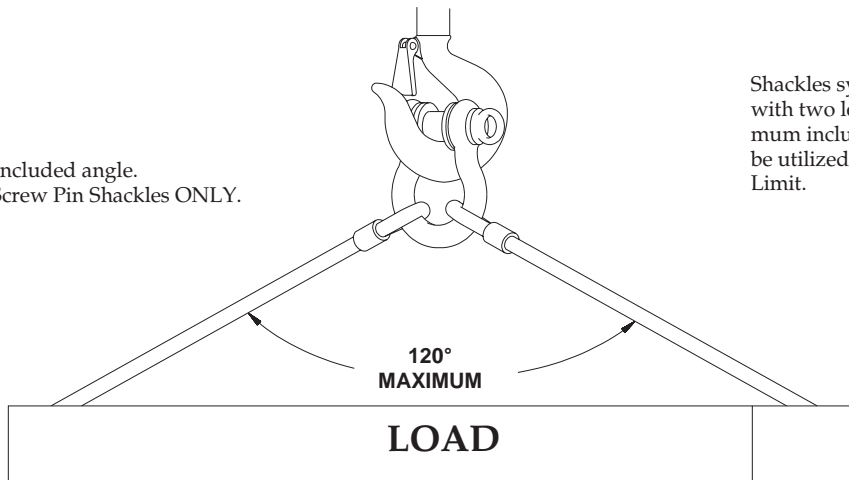

Shackles symmetrically loaded with two leg slings having a maximum included angle of 120° can be utilized to full Working Load Limit.

